

# Vertera<sup>TM</sup>

## Teller cash recycler

Enhanced banknote authentication and fitness sorting

The optimisation of cash management calls for specialist experience, resources and truly innovative technology. Across the world, Talaris' cash management solutions are trusted by thousands of organisations to ensure their cash is managed securely and efficiently whilst delivering the ultimate in productivity.

Talaris have in excess of 250 patents granted across 26 countries and are world experts in optimal cash handling solutions. 2,300 Talaris professionals, including over 1,000 service and support staff and 130 business partners cover over 100 countries delivering these solutions - wherever money moves.

The Vertera cash recycler from Talaris represents a significant evolution in teller automation technology, enabling financial institutions to focus on service excellence together with increasing customer engagement.

The Vertera series builds directly on the reputation of the leading cash recycling system – the pioneering and highly acclaimed TCR Twin Safe®. The Vertera, however, offers significantly enhanced banknote authentication, increased performance and the ability to drive down operational cost – all in a compact device that is easily incorporated into the branch.



The Vertera delivers real business benefit at multiple levels and provides a comprehensive and integrated solution to address the demands of the customer, the teller and improvements in branch efficiency.

- Provides a fast, efficient service for customers with fewer queues and a more personalised service that only a fully supported and attentive teller can provide
- Reduces monotonous and repetitive tasks as the Vertera provides a highly efficient and secure cash recycling solution
- Advanced authentication and fitness sorting capabilities, ensuring a robust first-line-of-defence for the bank branch
- Authenticity detectors are configured by Talaris to the specific currencies required and are configurable to customers requirements
- Optimises branch business processes with deployment flexibility designed into the solution, virtually eliminating start-of-day and end-of-day set up activities, and providing a consolidated view of the branch cash holding
- Compact design that provides the flexibility to fit seamlessly into the working environment, whether tellers are standing, sitting or mixed mode
- Fifth generation recycling technology providing trusted reliability and performance

## Talaris Technology

Talaris' unique technology sets new industry standards



High performance technology platform for banknote authentication and fitness sorting.

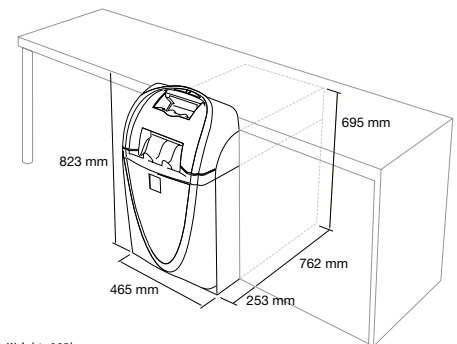

Weight: 385kg

Weight and dimensions shown are for an 8 RSM model with a UL 291 safe. Data for other configurations will vary, please contact your nearest Talaris office for details.

## Product specification

Roll storage system	6 or 8 roll storage modules	Users	One or two users
Capacity	Up to 400 notes or 600 notes per module	Detector options	Visible Infrared Ultraviolet Magnetic ink Tape/Repair
Safe	Available as 3 mm steel (designed to SS-EN14450:2005) UL 291 24 hrs Level 1 CEN (WG) III	Options	Safemaster for foreign currencies and cheques Journal printer Uninterruptible power supply Additional RS232 C interfaces Connectivity to all open network architectures Two drop deposits LAN network interface unit Connectivity software
Connectivity	RS232 C serial ports (2 standard/2 optional) Printer port Option: Additional PC Option: USB ports, LAN/Ethernet Option: Safemaster interface Option: Alarm connectivity		
Power supply	100 - 240V AC, 47 - 63 Hz		
Power consumption	600W		

Talaris House  
Crockford Lane  
Chineham Business Park  
Basingstoke, Hampshire  
RG24 8QZ, UK

T +44 (0)1256 368000  
F +44 (0)1256 368001  
info@uk.talaris.com  
www.talaris.com



DS-VERTERA-0509